

**VARIABLE ORIFICE
BALANCING VALVE**

cim 786OT

PN 25

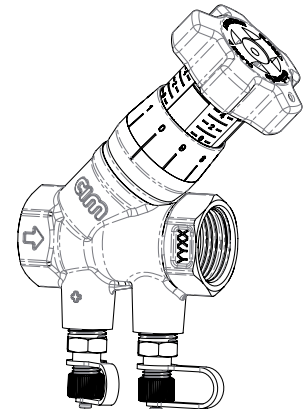

Main features:

Cim 786OT is used for balancing the flow in cooling, heating and domestic water systems. Cim 786OT is a combined manual presetting valve with following features:

- Variable measurement orifice;
- Supplied with 2 pcs. of measuring nipples for needles;
- Handwheel with shut-off function and clear 360° reading;
- Digital scale with lock function;
- High measuring accuracy.

It is supplied with internal thread.

This article is made in compliance with the quality management requirements of ISO 9001:2008 standard.

All articles are tested according to EN 12266-1:2003 standard.

It can be used in a wide variety of sectors: heating, air conditioning, water, sanitary systems and generally with any non corrosive liquid.

Technical data:

Max. static working pressure	25 bar
Max. flow temperature	120 °C
Min. temperature	-10°C
Fluids:	Water and Glycol
Material of parts in contact with water:	Valve body; Spindle; Cone, etc.
Materials:	Brass Alloy (EN 12165-CW617N-M)
O-rings:	EPDM Perox
Threads:	ISO 228

Approved by:



TECHNICAL DATA SHEET

Models:

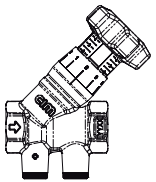
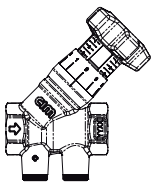
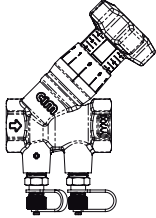

Cim 786OT - Balancing valve - Variable orifice - PN 25

DN	Material	Thread	Kv - Kvs	Technical Code
15	Brass Alloy EN 12165-CW617N-M	G. 1/2"	0.64 ÷ 3.94	DA03871015
20		G. 3/4"	0.50 ÷ 5.33	DA03871020
25		G. 1"	0.34 ÷ 8.92	DA03871025
32		G. 1"1/4	1.02 ÷ 16.68	DA03871032
40		G. 1"1/2	4,08 ÷ 25.12	DA03871040
50		G. 2"	5,22 ÷ 36.98	DA03871050

Cim 786OT/2OT - Balancing valve - Variable orifice - PN 25 - with brass blind plugs

DN	Material	Thread	Kv - Kvs	Technical Code
15	Brass Alloy EN 12165-CW617N-M	G. 1/2"	0.64 ÷ 3.94	DA03881015
20		G. 3/4"	0.50 ÷ 5.33	DA03881020
25		G. 1"	0.34 ÷ 8.92	DA03881025
32		G. 1"1/4	1.02 ÷ 16.68	DA03881032
40		G. 1"1/2	4.08 ÷ 25.12	DA03881040
50		G. 2"	5,22 ÷ 36.98	DA03881050

Cim 786OT/2NYL - Balancing valve - Variable orifice - PN 25 - with Nylon blind plugs

DN	Material	Thread	Kv - Kvs	Technical Code
15	Brass Alloy EN 12165-CW617N-M	G. 1/2"	0.64 ÷ 3.94	DA03891015
20		G. 3/4"	0.50 ÷ 5.33	DA03891020
25		G. 1"	0.34 ÷ 8.92	DA03891025
32		G. 1"1/4	1.02 ÷ 16.68	DA03891032
40		G. 1"1/2	4.08 ÷ 25.12	DA03891040
50		G. 2"	5,22 ÷ 36.98	DA03891050

TECHNICAL DATA SHEET

Cross section:

1. Valve body
2. Bonnet
3. Stem
4. Gasket
5. Shutter
6. Index
7. Entrainer
8. Knob
9. Tenth turn index
10. Screw
11. O-ring
12. Binder point
13. Red cap
14. Blue cap
15. O-ring

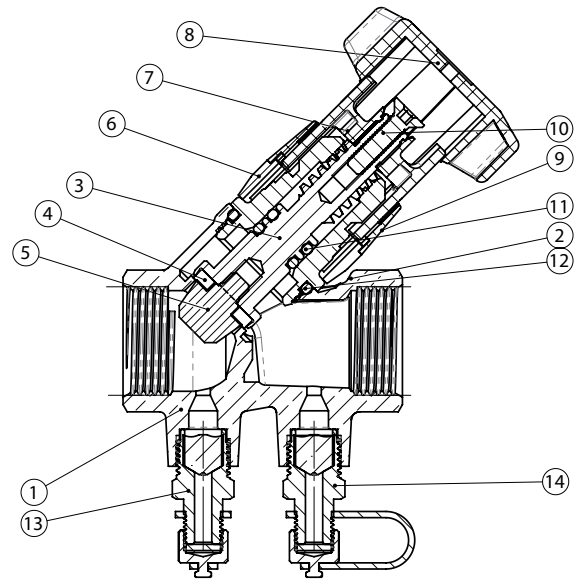

Installation procedure:

Before installation of Cim 786OT, check that inside the valve and the pipes there are no foreign matters which might damage the tightness of the valve.

When installing the valve, please make sure to have a pipe length 5 times the DN upstream the valve and 2 times the DN downstream, and pay attention to the arrow direction casted on the valve body, which shall be the same as the flow one.

Burr pipe connections after having threaded them and distribute the sealing material on pipe threads only and not on valve threads. The sealing material quantity shall be according to the dimension of parts to be coupled. An excessive quantity of sealing material could submit the threaded ends to extreme stress and/or fall inside the valve and cause problem to the flow.

For assembly purposes, use a spanner, not a pipe wrench, by applying necessary working torque only on the valve end nearest the pipe. This helps get a firmer grip and avoids potential damages to valve body.

Make sure that pipe threading length is not longer than valve threads.

TECHNICAL DATA SHEET

Regulating:

To close the valve, rotate clockwise the handle until the stop. Looking at the data showed in the herewith attached diagrams, it is possible to regulate the flow by rotating the handle anticlockwise until the required flow rate is reached. The reading of this flow rate can be done by using the differential manometer Cim 726.

This interfaces with the balancing valve through two sensors inserted in the binder points placed before and after the calibrated diaphragm of the valve.

The main index scale showing values from 0 up to 4 of the handle, states the turns of opening of the obturator, while the second circular one from 0 up to 9 registers the tenths of one turn.

The position of the handle for the required flow rate can be memorized by an Allen Key 3 mm.

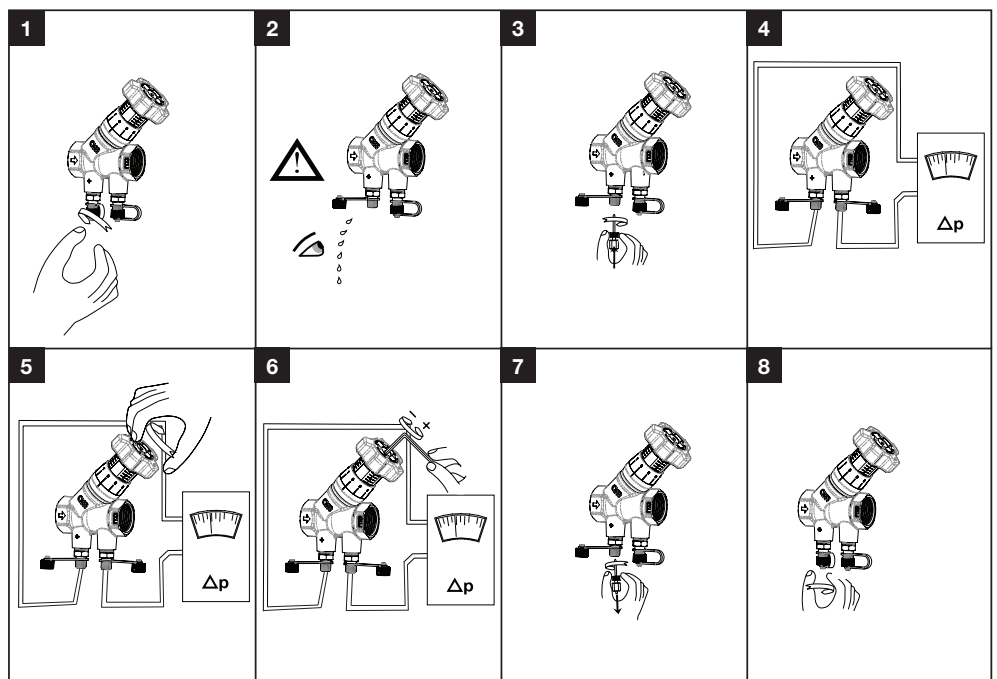

Sizing:

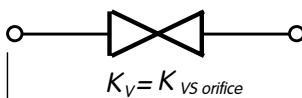

Kvs orifice - Kv across orifices
Kv - Kv across valve

Relative density	
Fluid	r
Water	1.000
Water and glycol 10%	1.012
Water and glycol 20%	1.028
Water and glycol 30%	1.040
Water and glycol 40%	1.054
Water and glycol 50%	1.067

FLOW COEFFICIENT

Kv, in metric system represents the flow in m³/h of water at the temperature of 15.5°C (density =998 kg/m³) which causes a pressure drop of 1 bar. In the USA flow coefficient is called Cv (Kv = 0.865 Cv).

$$Kv = \frac{Q}{\sqrt{\Delta p}}$$

It is possible to calculate the pressure drop across a valve with a generic flow rate and fluid:

$$\Delta p = r \cdot \left(\frac{Q}{kv}\right)^2$$

where:

r is the relative density, Q is the flow rate in m³/h.

TECHNICAL DATA SHEET

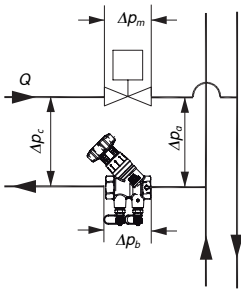

$$\Delta p_o = \Delta p_b + \Delta p_c + \Delta p_m$$

- Δp_b Pressure drop across Cim 786OT
- Δp_m Pressure drop across the control valve
- Δp_c Necessary pressure for the circuit
- Δp_o Available pressure for the riser

SUGGESTED VALUES AND TIPS:

- Pressure drop across the valve:
Max = 50 kPa
- Pressure drop across the binders:
Max = 50 kPa
Min = 1 kPa
- Velocities in the pipeline:
Max = 1.15 m/s
Min = 0.75 m/s

For the preliminary sizings where the value of pressure drop across the valve is not known, use a value of 10 kPa.

EXAMPLE

It is required to balance the circuit in the figure, the given data are:

- Necessary pressure for the circuit: $\Delta p_c = 13 \text{ kPa}$;
- Available pressure for the riser: $\Delta p_o = 35 \text{ kPa}$;
- Pressure drop across the control valve: $\Delta p_m = 10 \text{ kPa}$;
- Flow rate: $Q = 0.3 \text{ m}^3/\text{h} = 0.083 \text{ l/s}$.

The required differential pressure across the balancing valve can be calculated using the following relation:

$$\Delta p_b = \Delta p_o - \Delta p_m - \Delta p_c = 35 - 10 - 13 = 12 \text{ kPa} = 0.12 \text{ bar}$$

the required Kv is:

$$Kv = Q \cdot \sqrt{\frac{r}{\Delta p_b}} = 0.3 \cdot \sqrt{\frac{1}{0.12}} = 0.87$$

Using the attached tables to this datasheet, it is possible to find the following available valves with the relative position of the handle:

- Cim 786OT DN 15 --> Preset: 0.4 (Kv=0.89);
- Cim 786OT DN 20 --> Preset: 0.5 (Kv=0.94);
- Cim 786OT DN 25 --> Preset: 0.4 (Kv=0.89);

The two selected models are comparable. As a general rule, it is better to choose the valve with the smallest diameter, in this way the valve will be quite opened and there will be no problem with noises and cavitations.

Measuring the pressure drop across the binders of the Cim 786OT DN 15 (Preset 0.4), the operator will find this value:

$$Kv = r \cdot \left(\frac{Q}{Kvs}\right)^2 = 1 \cdot \left(\frac{0.3}{0.89}\right)^2 = 0.114 \text{ bar} = 11.4 \text{ kPa}$$

N.B. The Kvs value is equal to the Kv of the valve and the measured pressure drop across the binders is the pressure drop across the valve too.

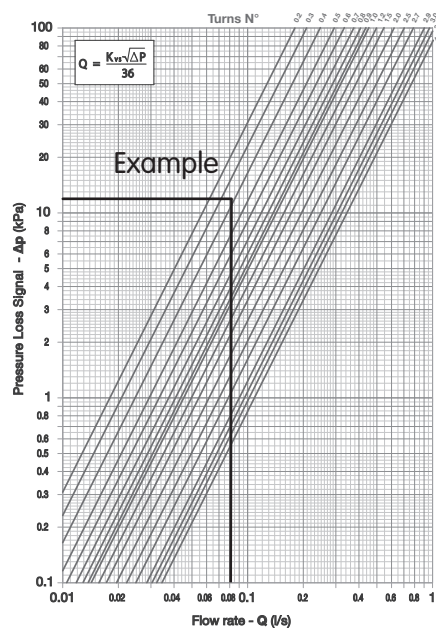

TECHNICAL DATA SHEET

Measurement conversion chart:

Pressure

FROM	MULTIPLY BY	TO OBTAIN
Pa, Pascal	0,001	kPa, kiloPascal
Pa, Pascal	0,000001	MPa, Mega Pascal
Pa, Pascal	0,00001	bar
Pa, Pascal	0,00010972	m _{H2O} , metres of water
Pa, Pascal	0,000145038	psi, pound per square inch
bar	1,01325	atm, atmosphere
bar	0,980665	Kg/cm ² , kilograms per square centimetre
bar	10,1972	m _{H2O} , metres of water
bar	14,5038	psi, pound per square inch
atm, atmosphere	1,03323	Kg/cm ² , kilograms per square centimetre
atm, atmosphere	10,3323	m _{H2O} , metres of water
atm, atmosphere	14,6959	psi, pound per square inch
Kg/cm ²	10	m _{H2O} , metres of water
Kg/cm ²	14,2233	psi, pound per square inch
m _{H2O}	1,42233	psi, pound per square inch

← TO OBTAIN DIVIDE BY FROM →

Length, Area, Volume, Density

FROM	MULTIPLY BY	TO OBTAIN
inches	0,0254	m, metres
inches	2,54	cm, centimetres
feet	0,3048	m, metres
feet	30,48	cm, centimetres
yards	0,9144	m, metres
square inches	0,00064516	m ² , metri quadrati
square feet	0,09290304	m ² , square metres
square inches	6,4516	cm ² , square centimetres
square feet	929,0304	cm ² , square centimetres
square yards	0,8361274	m ² , square metres
l, litres	0,001	m ³ , cubic metres
gallons	0,003789412	m ³ , cubic metres
cubic yards	0,7645549	m ³ , cubic metres
cubic feet	0,02831685	m ³ , cubic metres
cubic inches	0,0000164	m ³ , cubic metres
cubic inches	16,38706	cm ³ , cubic centimetres
cubic feet	28,31685	l, litres
gallons	3,875412	l, litres

← TO OBTAIN DIVIDE BY FROM →

Pressure-temperature ratings:

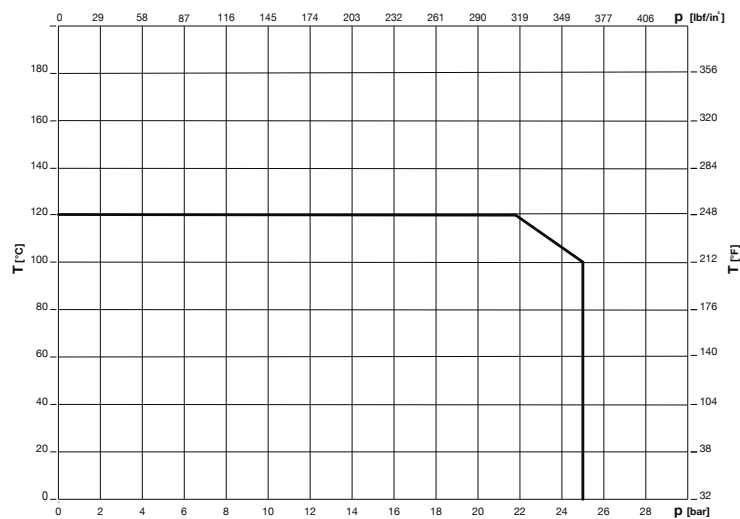

TECHNICAL DATA SHEET

Kv Values - DN 15

Cim 786OT
Cim 786OT/2OT
Cim 786OT/2NYL

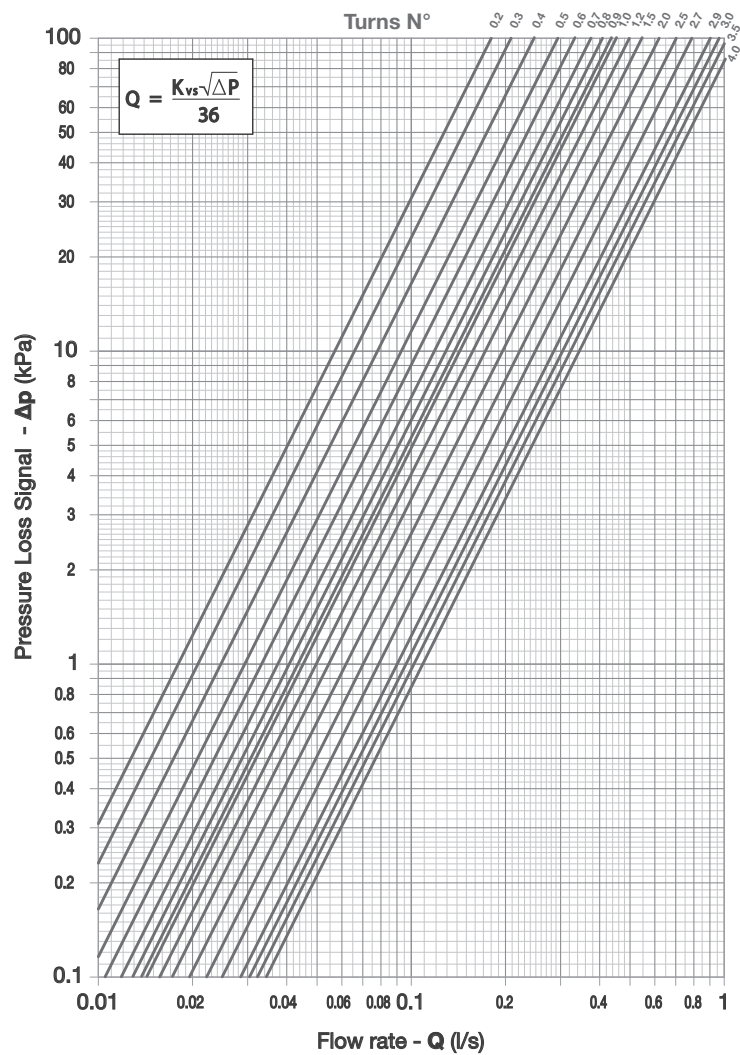
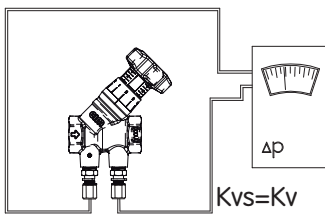

Kv-Kvs (Flow rate in m ³ /h @ 1 bar pressure drop)										
Full turn	Tenths of turn									
	0.0	0.1	0.2	0.3	0.4	0.5	0.6	0.7	0.8	0.9
0	-	-	0.64	0.75	0.89	1.06	1.20	1.35	1.47	1.57
1	1.63	1.71	1.79	1.88	1.96	2.01	2.09	2.14	2.16	2.21
2	2.23	2.26	2.29	2.37	2.45	2.53	2.68	2.82	3.04	3.25
3	3.47	3.51	3.55	3.59	3.64	3.68	3.73	3.79	3.84	3.89
4	3.94									

TECHNICAL DATA SHEET

Kv Values - DN 20

Cim 786OT
Cim 786OT/2OT
Cim 786OT/2NYL

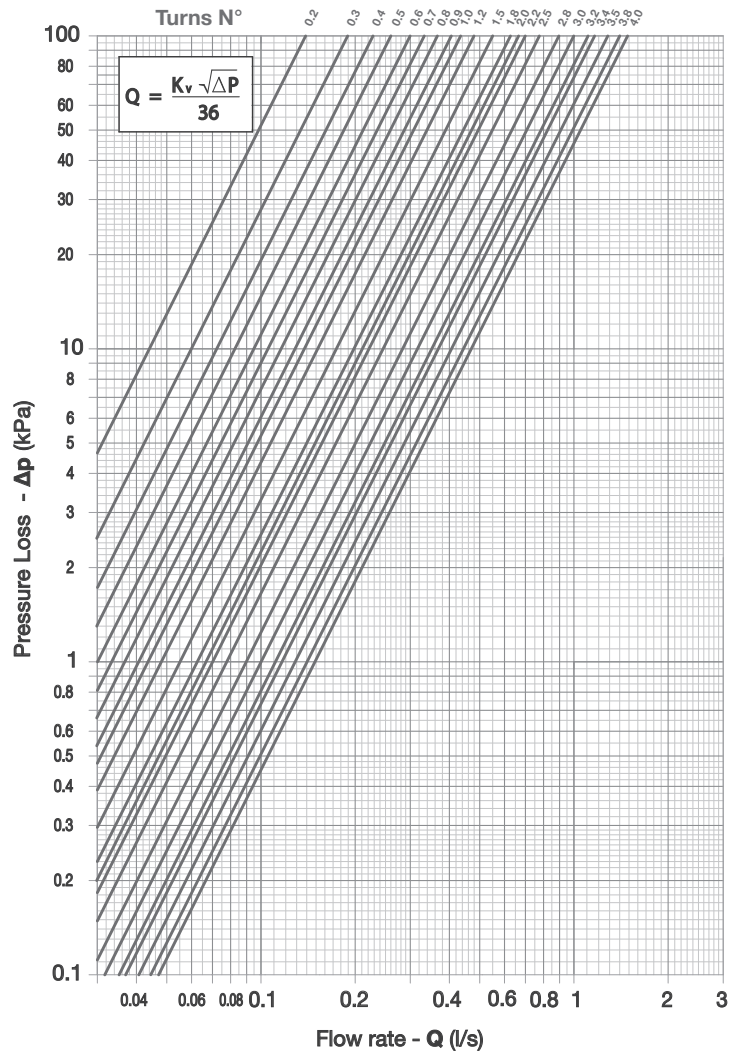
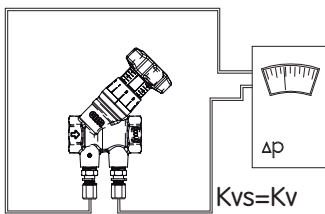

Kv-Kvs (Flow rate in m ³ /h @ 1 bar pressure drop)										
Full turn	Tenths of turn									
	0.0	0.1	0.2	0.3	0.4	0.5	0.6	0.7	0.8	0.9
0	-	-	0.50	0.68	0.82	0.94	1.08	1.20	1.32	1.46
1	1.57	1.65	1.73	1.83	1.92	2.00	2.10	2.17	2.26	2.35
2	2.40	2.46	2.52	2.61	2.70	2.79	2.93	3.06	3.23	3.41
3	3.58	3.79	4.00	4.20	4.41	4.62	4.76	4.90	5.05	5.19
4	5.33									

TECHNICAL DATA SHEET

Kv Values - DN 25

Cim 786OT
Cim 786OT/2OT
Cim 786OT/2NYL

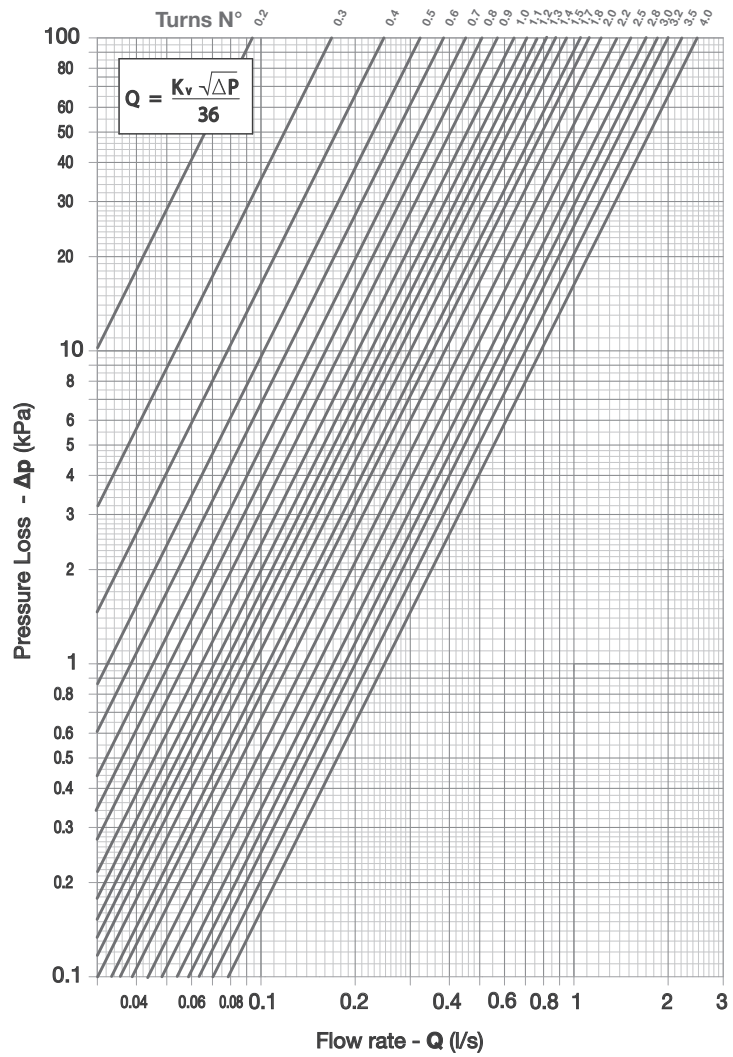
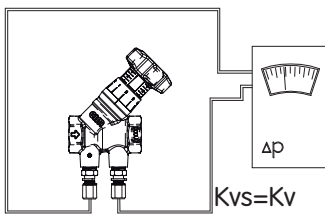

Kv-Kvs (Flow rate in m ³ /h @ 1 bar pressure drop)										
Full turn	Tenths of turn									
	0.0	0.1	0.2	0.3	0.4	0.5	0.6	0.7	0.8	0.9
0	-	-	0.34	0.61	0.89	1.16	1.38	1.61	1.82	2.05
1	2.31	2.54	2.75	2.95	3.15	3.41	3.59	3.78	4.01	4.24
2	4.40	4.67	4.93	5.12	5.31	5.51	5.66	5.81	6.10	6.38
3	6.66	6.92	7.17	7.43	7.68	7.94	8.13	8.33	8.53	8.72
4	8.92									

TECHNICAL DATA SHEET

Kv Values - DN 32

Cim 786OT
Cim 786OT/2OT
Cim 786OT/2NYL

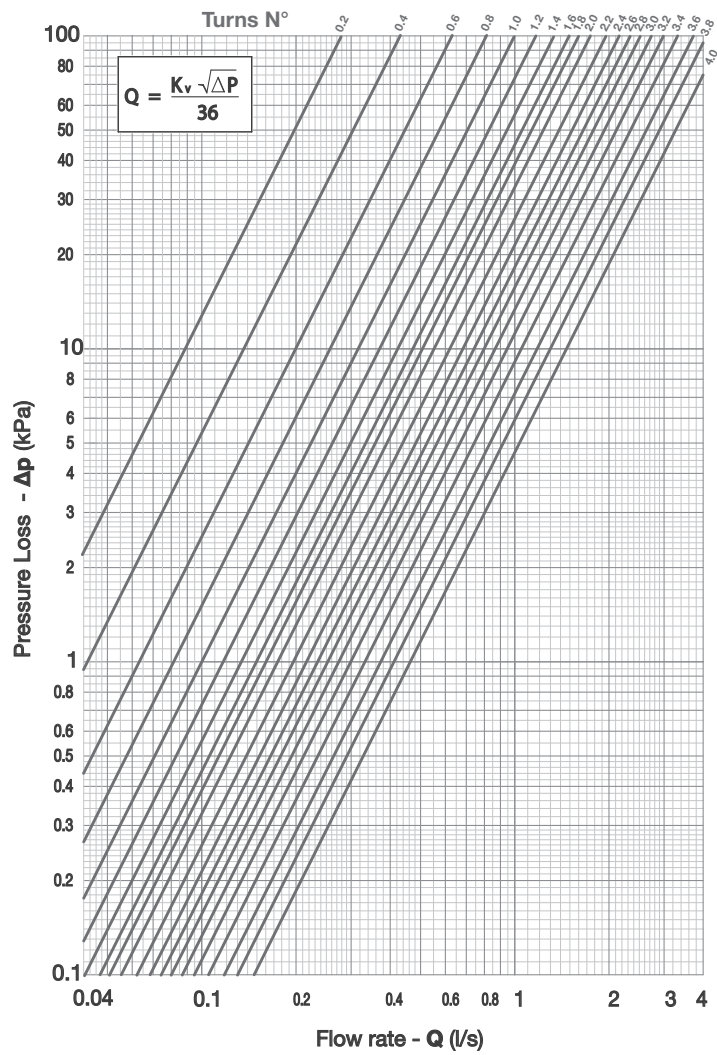
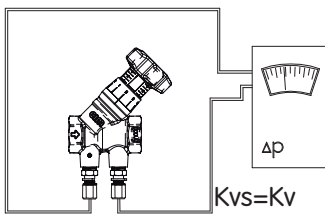

Kv-Kvs (Flow rate in m³/h @ 1 bar pressure drop)

Full turn	Tenths of turn									
	0.0	0.1	0.2	0.3	0.4	0.5	0.6	0.7	0.8	0.9
0	-	-	1.02	1.29	1.57	1.94	2.28	2.62	2.95	3.26
1	3.57	3.88	4.17	4.50	4.81	5.07	5.34	5.58	5.77	6.02
2	6.28	6.66	7.04	7.41	7.79	8.16	8.41	8.66	9.06	9.45
3	9.85	10.35	10.85	11.35	11.85	12.35	13.22	14.08	14.95	15.81
4	16.68									

TECHNICAL DATA SHEET

Kv Values - DN 40

Cim 786OT
Cim 786OT/2OT
Cim 786OT/2NYL

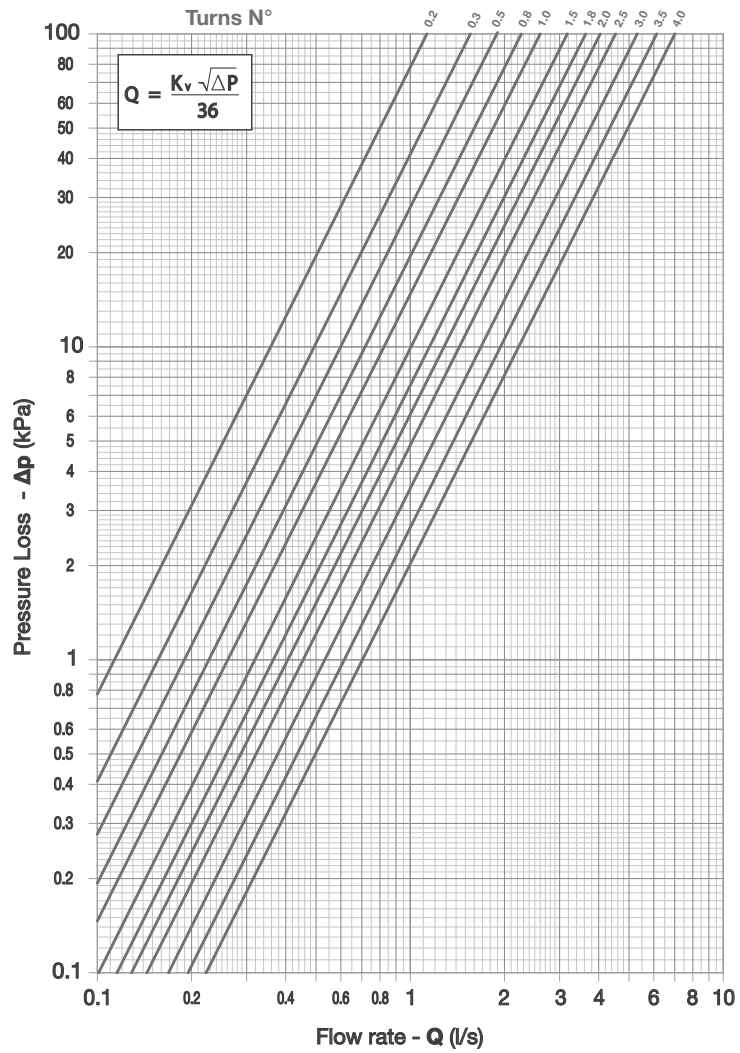
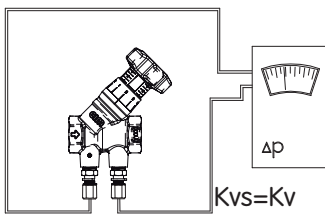

Kv-Kvs (Flow rate in m³/h @ 1 bar pressure drop)

Full turn	Tenths of turn									
	0.0	0.1	0.2	0.3	0.4	0.5	0.6	0.7	0.8	0.9
0	-	-	4.08	5.94	6.53	6.81	7.19	7.23	8.10	8.79
1	9.26	9.80	10.45	10.95	11.63	12.17	12.54	12.69	13.13	13.81
2	14.48	14.59	14.70	15.23	15.77	16.30	16.91	17.51	18.02	18.54
3	19.05	19.63	20.20	20.78	21.35	21.93	22.57	23.21	23.84	24.48
4	25.12									

TECHNICAL DATA SHEET

Kv Values - DN 50

Cim 786OT
Cim 786OT/2OT
Cim 786OT/2NYL

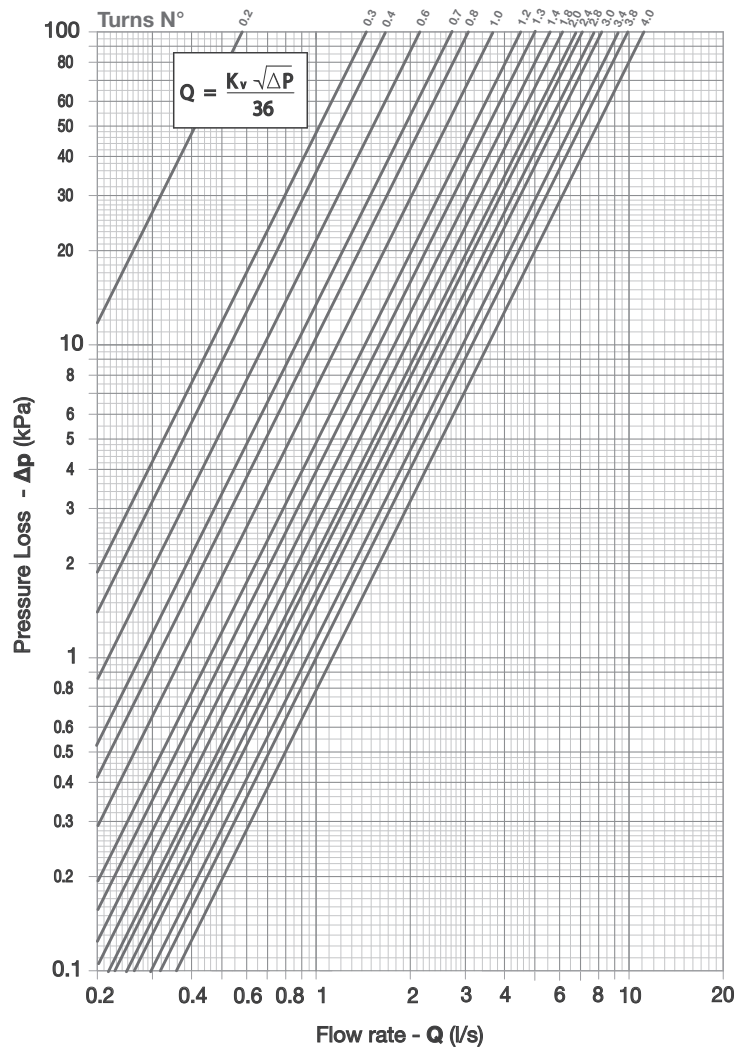
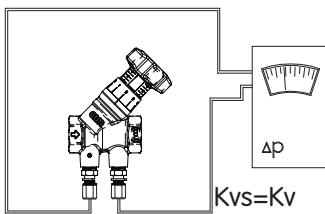

Kv-Kvs (Flow rate in m³/h @ 1 bar pressure drop)

Full turn	Tenths of turn									
	0.0	0.1	0.2	0.3	0.4	0.5	0.6	0.7	0.8	0.9
0	-	-	-	5,22	6,07	7,04	8,12	9,80	11,00	12,11
1	13,05	14,77	16,23	17,90	19,97	20,15	21,11	21,87	22,16	23,25
2	24,35	24,46	24,55	25,13	25,54	25,76	26,53	26,87	27,73	28,76
3	29,57	31,90	31,51	32,92	33,47	34,36	34,82	35,36	35,87	36,03
4	36,98									

TECHNICAL DATA SHEET

Main dimensions:

Cim 786OT

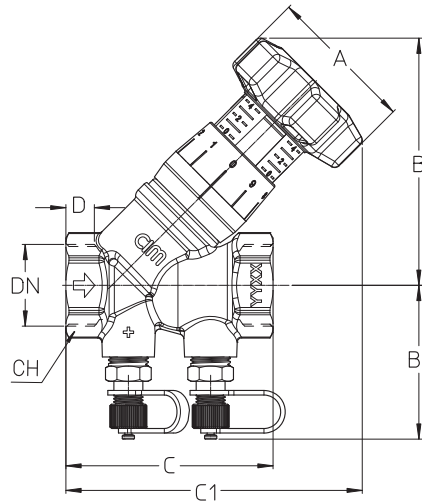

DN	15	20	25	32	40	50
Grms.	380	430	535	840	1400	1645
A	50	50	50	50	50	50
B	83	81	83	87	107	104.5
B1	53.5	57.5	59.5	65	64	70
C	59	68	85	109	123	141
C1	92	96	115	118	134	146
D	12.5	12.5	14.5	16	16	19
CH	25	31	38	47	55	66

Main dimensions:

Cim 786OT/2OT
Cim 786OT/2NYL

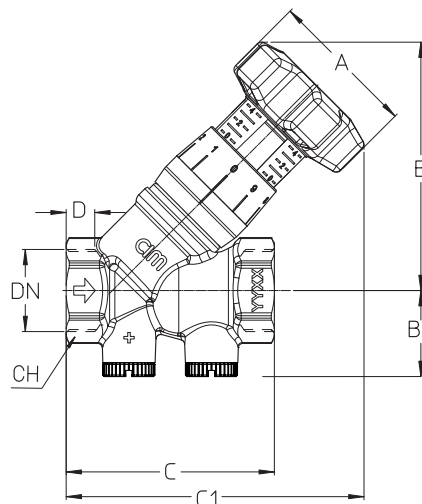

DN	15	20	25	32	40	50
Grms.	365	420	520	825	1390	1625
A	50	50	50	50	50	50
B	83	81	83	87	107	104.5
B1	31	35	37	42,5	41,5	70,5
C	59	68	85	109	123	141
C1	92	96	115	118	134	146
D	12.5	12.5	14.5	16	16	19
CH	25	31	38	47	55	66

TECHNICAL DATA SHEET

Maintenance

As a rule, the balancing valve does not need any maintenance. In case of replacement or need of disassembling of some components of the valve, make sure that the installation is not under service or pressure.

Should you need to replace the tightening OR (15) between body (1) and bonnet (2), follow the instructions given here below:

- Open the obturator partially (5)
- Lift the index scale (9) placed over the handle (8), unthread the handle (8) and the reference ring (6);
- Unscrew the bonnet (2) with a key, acting on the hexagonal side;
- Replace the Oring (15)
- Open the obturator (5) until the maximum opening;
- Screw the bonnet (2) on until its fastening on the valve body (1) with a key acting on the hexagonal side;
- Insert the reference ring (6) and the handle (8) in their site, acting on the valve body;
- Close the valve completely by turning the handle clockwise;
- When the valve is closed, the index scale (9) shall be placed with the "0" value in correspondence with the sign marked on the reference ring (6).

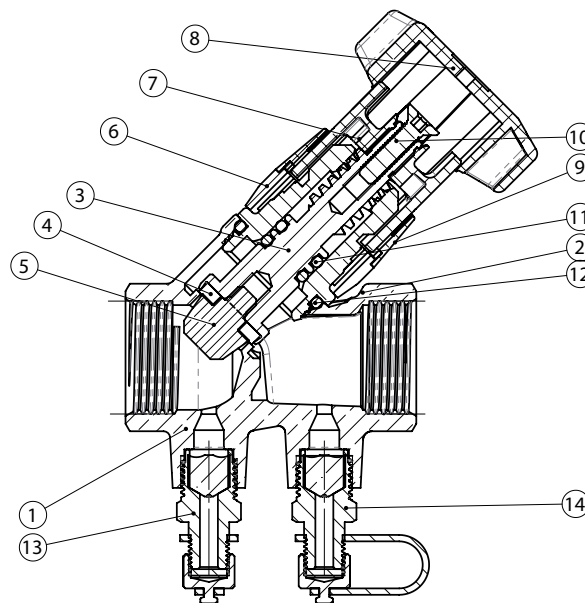

TECHNICAL DATA SHEET

cav. uff. **GIACOMO CIMBERIO**
s.p.a.

28017 San Maurizio d'Opaglio (NO) - Italy - Via Torchio, 57 - C.P. 106
Tel. +39 0322 923001 - Fax: +39 0322 967216 / 967755
skype: cimberiosk1, cimberiosk2

info@cimberio.it

www.cimberio.com

© Copyright - Cav. Uff. GIACOMO CIMBERIO S.p.A. - All rights reserved. Tutti i diritti riservati.



IMR 562637



FM 01820



SA 551551



EMS 551553



OHS 551552



ENMS 577357